

# yuwell

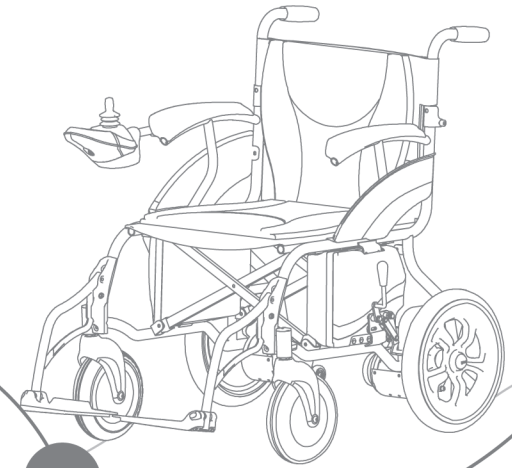

## Electric Wheelchair

D210B / D210BL

D210D / D210DL

### Product Operation and Technical Instructions

Please carefully read these instructions before using the product

Please refer to the qualification certificate or outer packaging for date of manufacture



JIANGSU YUYUE MEDICAL EQUIPMENT & SUPPLY CO.,LTD.  
No.1 Baisheng Road Development Zone, Danyang,  
Jiangsu 212300 CHINA



Metrax GmbH  
Rheinwaldstr. 22, D-78628 Rottweil, Germany



530817-1A 

## Table of Contents

1. Preface.....	01
2. Safety Overview.....	01
3. Product Characteristics.....	03
4. Description of Symbols.....	05
5. Unpacking and Installation.....	06
6. Directions For Use.....	09
7. Daily Maintenance and Service.....	14
8. Transportation and Storage.....	19
9. Failure Diagnosis and Handling.....	20
10. Electromagnetic Compatibility.....	23
11. After-sales Service.....	27
12. Supplementary Instructions.....	28

### 1. Preface

Hello Customer!

- Thank you for your love of Yuyue and for purchasing a Yuyue Electric Wheelchair. The electric wheelchair carefully developed by Yuyue is light and convenient, efficient and energy-saving. It is flexible and safe to operate, and is well received by the majority of users.
- Before use, please carefully read these instructions so that you can better understand various functions of the electric wheelchair for better control. You should carry out the maintenance and service as required to ensure that the wheelchair is in good condition.
- For any questions, please contact the dealer or manufacturer and we will serve you wholeheartedly!

### 2. Safety Overview

- ⓘ Do not operate your electric wheelchair before reading and fully understanding these instructions.
- ⓘ Do not operate your electric wheelchair before the assembly and inspection are completed.
- ⓘ It is recommended that persons with unsound minds, slow responses and operational difficulties should not use the electric wheelchair.
- ⓘ Do not disassemble or modify the electric wheelchair or use any replacement parts not manufactured by the company.
- ⓘ Do not get into or out of the electric wheelchair when the controller is powered on or the electric wheelchair is in the manual mode and is not fixed by the pusher.
- ⓘ Do not use the electric wheelchair when the anti-roll wheel is not open or has broken down.
- ⓘ Do not tilt or lift the electric wheelchair to one side when it is being operated normally.
- ⓘ Do not stand on the pedal to prevent the electric wheelchair from rolling over.

- ⊗ Do not turn or steer on an incline.
- ⊗ To avoid accidents, the electric wheelchair should not be operated by two persons simultaneously.
- ⚠ The moving electric wheelchair should be decelerated to below 2 km/h before turning.
- ⚠ Drive carefully in the lowest gear when going downhill; Drive cautiously at low speed and lean forward properly when going uphill.
- ⚠ Do not sit in the electric wheelchair when it is being transported.
- ⊗ Please check whether the wheel connections are secure and reliable.
- ⚠ Pull the controller joystick gently and do not pull back and forth on it rapidly.
- ⊗ The controller is the core part of the electric wheelchair. Do not park the electric wheelchair in the open air for a long time. The electric wheelchair should be parked indoors when it rains, to avoid moisture.
- ⚠ Before powering on the controller, confirm that the "Manual/Electric" handle of the left and right motors is in the "Electric" gear.
- ⚠ Do not switch the "Manual/Electric" handle of the motor to the "Manual" position while the wheelchair is running; if it is necessary to use radio communication devices such as mobile phones or laptops while in the electric state, please turn off the controller power of the electric wheelchair.
- ⊗ The electric wheelchair is suitable for flat ground and low inclines. Avoid driving on pavement with a slope greater than 6 degrees and driving over obstacles more than 4 cm high.
- ⚠ It is strictly forbidden to cross places with horizontal gaps, such as sewers.
- ⚠ If the electric wheelchair is not used for a long time, turn off the power switch on the battery box.
- ⚠ This company's electric wheelchair is suitable for using outdoors, but can only be used in neighborhoods.
- ⊗ Contraindications: None
- ⊗ This electric wheelchair shall not be operated on the road, otherwise it is easy to cause traffic accidents.

### 3. Product Characteristics

#### 1. Scope of application

- This company's electric wheelchair is suitable for the disabled with difficulties walking and the elderly and infirm.

#### 2. Product components

- The product is composed of a frame, controller, motor, battery, pedal, handrail, front wheels and rear wheels.

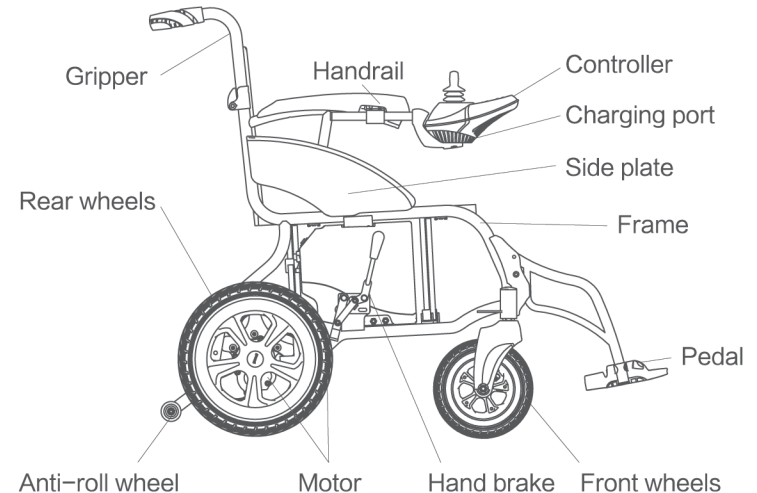

Refer to Figure 1 for the product's structural diagram

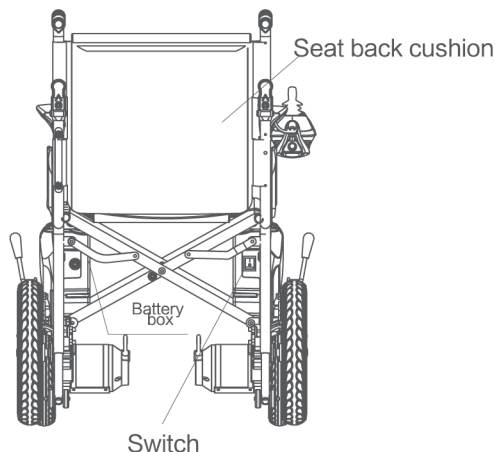

Refer to Figure 2 for the product's structural diagram

### 3. Structural characteristics

- Motor: energy-saving and efficient.
- Frame: easy to assemble and disassemble, foldable.
- Intelligent controllers: power button, power display, universal joystick, horn.
- Electromagnetic braking system: safe and reliable.
- Anti-roll device.
- Battery: fully-sealed, maintenance-free.
- Two modes of operation: automatic electric drive mode and power boost mode.

### 4. Technical parameters

1. Product type: outdoor model
2. Max. speed:  $\leq 6\text{km/h}$
3. Ambient operating temperature:  $-25^{\circ}\text{C}\sim+50^{\circ}\text{C}$
4. Load capacity:  $\leq 100\text{kg}$
5. Braking performance on horizontal plane:  $\leq 1.5\text{m}$













6. Endurance mileage:  $\geq 20\text{km}$
7. Max. safety slope braking:  $\leq 3.6\text{m}$  ( $6^{\circ}$  )
8. Battery: lithium battery DC 24Vx18Ah;  
lead acid battery DC 24Vx20Ah
9. Obstacle clearance height:  $\geq 40\text{mm}$
10. Groove clearance width: 100mm
11. Gradeability:  $\geq 6^{\circ}$
12. Hill-holding performance:  $9^{\circ}$
13. Static stability:  $\geq 9^{\circ}$
14. Dynamic stability:  $\geq 6^{\circ}$
15. Min. turning radius: 1.2m

The above parameters will vary depending on the weight of the occupant, road conditions and battery usage

- Normal working conditions:
  - Ambient temperature range:  $-25^{\circ}\text{C}\sim+50^{\circ}\text{C}$
  - Relative humidity range: 25%~95%
  - Atmospheric pressure range: 86kPa~106kPa
- Internal power supply: DC24V $\pm$ 5V
- Internal power supply equipment
- Electrical requirements: type B application part
- Mode of operation: continuous operation
- Fluid ingress protection degree: IPX4
- Motor power: about 210W for both left and right motors
- This equipment cannot be used in flammable anesthetic gas mixed with air or flammable anesthetic gas mixed with oxygen or nitrous oxide.

### 4. Description of Symbols

Symbols related to safety requirements of the electric wheelchair and their meaning

Symbols	Meaning	Symbols	Meaning
	Type B application part		Up
	Rain-proof		No rolling-over
	Fragile: please handle carefully		Stacking layers limit
	Manufacturer		Refer to instruction manual
	This device fulfils the provisions of (EU) 2017/745 (Medical Device Regulation)		
IPX4	Splash-proof: a water splash in any direction will not cause any harmful effect		
	Note! Check the document attached to the electric wheelchair		
	The pollution control mark of electronic information products, indicating that the environmental-protection use period is 10 years, except for consumables		
	ⓘ This sign indicates the mandatory contents (must be observed). The specific mandatory contents are expressed in words or drawings in or near. The left figure indicates the "general mandatory contents"		
	⊘ This sign indicates the prohibited contents (not allowed). The specific prohibited contents are expressed in words or drawings in or near. The left figure indicates the "general prohibited contents"		

## 5. Unpacking and Installation

- Take the electric wheelchair out of the box. Lift up the folded backrest, press down on the seat back tubes at both sides, open the electric wheelchair until the seat cushion and back cushion are fully expanded. Refer to Figure 3, Figure 4, Figure 5 and Figure 6.

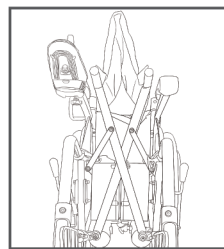

Figure 3

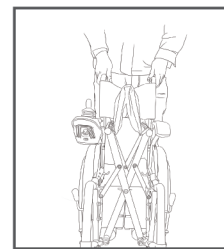

Figure 4

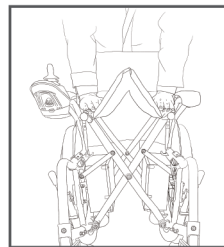

Figure 5

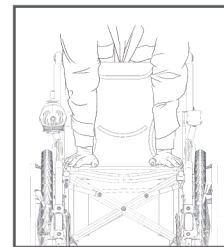

Figure 6

- Use of the backrest folding mechanism: hold the handle with both hands, lift up the backrest tube in a clockwise direction until the eject pin of the backrest folding device snaps into the eject pin hole, see Figure 7; pack up: press the buckle of the backrest folding device with your fingers, hold the backrest folding device with both hands. Fold it up in a counterclockwise direction after confirming that the eject pin has left the eject pin hole, see Figure 8.

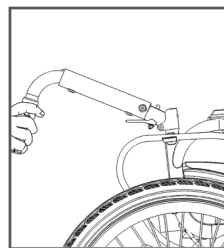

Figure 7

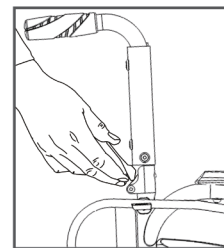

Figure 8

### Note

To avoid pinching, do not hold the seat tubes with your hands when pressing down the seat cushion.

### Note

To avoid pinching, do not put your fingers into the folded backrest.

- Reversible handrail: Press and hold the handrail buckle to separate the buckle from the frame, and then pull up the front end of the hand rail, as shown in Figure 9.
- Installation and disassembly of movable legs: 1. Align the buckle hole with the eject pin on the wheelchair, clasp the movable leg, and then rotate it in the direction of the arrow. When you hear a click, the installation is completed. 2. Installation of leg straps. Disassembly: 1 Remove the leg strap. 2. Open the buckle and rotate it outwards to remove it upwards. See Figure 10. Note: You must confirm that the movable leg is fixed to avoid accidents after it is installed.
- Adjustment of pedal height: loosen the set screws on the fastener with a hexagon wrench, adjust the pedal to the appropriate height according to the height of the occupant and lock the set bolts, see Figure 11.

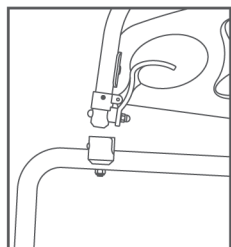

Figure 9

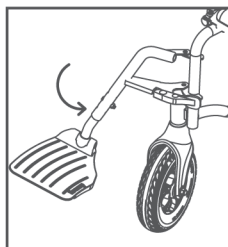

Figure 10

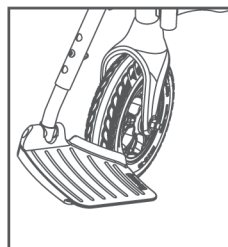

Figure 11

- Installation and removal of anti-roll wheel: Hold the marble on the anti-roll wheel with your fingers while installing and insert it into the frame hole until the marble fastens into the marble hole of the wheelchair. While removing, hold the marble with one hand and pull the anti-roll wheel off backwards with the other hand, see Figure 12 (After installation, the anti-roll wheel is about 4cm above the ground).
- Use of movable leg: when the electric wheelchair is provided with a movable leg, turn the movable leg from the position in Figure 11 to the position in Figure 12 along the rotational axis, ensuring that it rotates into the groove of the plastic part and open the pedal; the action sequence is reversed to folding back up. (Note: the function is only

suitable for models provided with a movable leg).

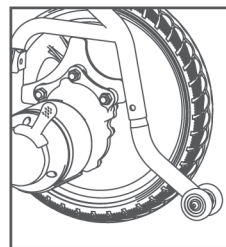

Figure 12

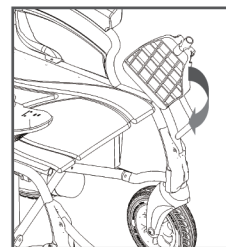

Figure 13

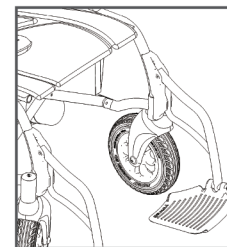

Figure 14

- Adjustment of controller: sit on the electric wheelchair, loosen the torx bolt, push the fixing rod of the controller backwards and forwards to the proper position and lock the torx bolt, see Figure 15. (The adjustment method is same if the controller is installed on the left side)

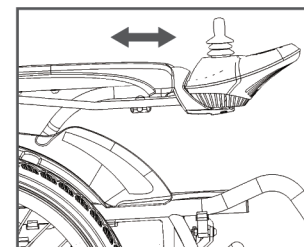

Figure 15

## 6. Directions For Use

### 1. Function description of controller

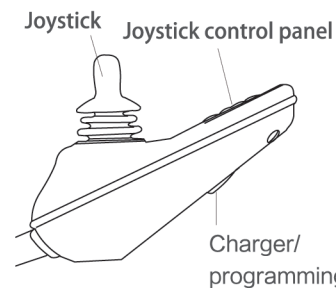

Figure 16

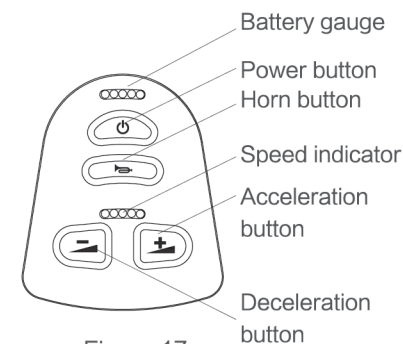

Figure 17

- Joystick

The joystick is mainly used to control the direction and speed of the wheelchair. The direction the joystick is pushed is the same as the direction of the wheelchair. The farther the joystick is pushed away from the center, the faster the wheelchair will move. The wheelchair will automatically brake when the joystick is released; when the wheelchair is stationary, do not push the joystick violently. Hold the joystick with your hand to move the electric wheelchair forwards and backwards and make turns. The electric wheelchair will automatically return and brake when the joystick is released.

- Battery gauge

The battery gauge is the indicator of the battery capacity. When the two green LED lights, one red light and one yellow light are on, it indicates the battery capacity is full. When two green LED lights are on, it indicates the battery capacity is sufficient. When only yellow or red LED lights are on, it indicates the battery capacity is not sufficient and please charge the wheelchair as soon as possible to ensure normal operation.

- Speedometer

It displays the maximum speed setting of the wheelchair. 5 speed settings are available: 1st gear: lowest; 5th gear: fastest.

- Horn button

Press this button to sound the horn.

- Acceleration button

Press this button to increase the speed setting. The gear increases by 1 each time you press this button and won't change after it reaches 5th gear.

- Deceleration button

Press this button to decrease the speed setting. The gear decreases by 1 each time you press this button and won't change after it reaches 1st gear.

### UDB interface

USB interface puts out 5V 0.5A.

## 2. Switching between electric driving and hand-pushing

When the wheelchair will be pushed manually instead of driven electrically, move the left and right motor clutch or handle to the "Manual" position; when driving electrically, switch the clutch or handle into the "Electric" position.

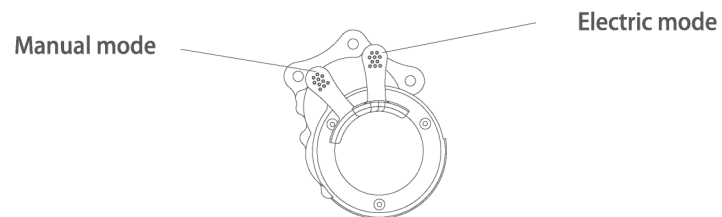

Figure 18

## 3. Charger

Customers are recommended to purchase the battery charger proposed by the company: lithium battery charger output DC24V2A or 3A. The charger shall meet the requirements of IEC60601-1.

### Note

- ▶ While charging, turn on the power switch on the battery box of the electric wheelchair and turn off the controller power button. Note: the power switch on the battery box is turned off when delivered. Make sure to turn on the power switch while charging. The switch is located on the back of the right battery box: "I": ON and "O": OFF, see Figure 19.

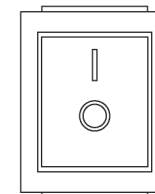

Figure 19

#### Note

- ▶ Insert the output plug of the charger into the lower slot of the controller, see Figure 20.

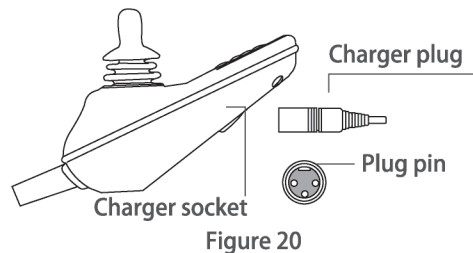

Figure 20

- ▶ To ensure the correctness of the circuit, do not arbitrarily change the circuit.
- ▶ To prevent burns or fires, do not disconnect the battery circuit during charging.

#### 4. Steps for normal driving

- Turn on the battery switch on the battery box and press "I" to switch it into normal operating condition, see Figure 19.
- Pull the clutch joystick of the two motors or the handle from the "Manual" to "Electric" position.

#### Note

Do not switch the clutch joystick on an incline. When switching on a level road, it is recommended to rotate the rear wheel slightly and then switch.

- Press the controller power button to check whether the electric wheelchair brakes effectively. If the wheelchair cannot be pushed, it indicates that the electronic brake is valid, otherwise you should contact the dealer or manufacturer.
- Lift the pedals up, sit in the electric wheelchair and then put the pedals down.

#### Note

Do not get into or out of the electric wheelchair by using the pedal. This may cause the electric wheelchair to tip over.

- Sit in the electric wheelchair, turn on the controller power (hold the button slightly for one second) and the indicator light will turn on. At this time, the joystick should be in the middle position. Focus your attention on the control of the wheelchair, which is especially important for first-time driving. Confirm that the handbrake is in the "non-braking" state before driving; the joystick can control the direction and speed simultaneously: the electromagnetic brake clicks and is released when you slowly push the joystick towards the driving direction, and the electric wheelchair will start moving; increase the pushing range of the joystick to accelerate, decrease the range to decelerate.
- If it is necessary to stop the moving electric wheelchair, just release and reset the joystick; if you suddenly pull the joystick or press the controller power button during forward movement, the wheelchair will quickly stop.
- When you stop on an incline, if the electromagnetic brake breaks down or the motor is in the "Manual" position or other special conditions occur, you can pull the hand brake in the direction as shown in Figure 21.

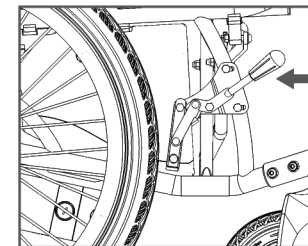

Figure 21

- The speed adjustment button of the controller can adjust the speed of the electric wheelchair. The occupant should select the maximum speed according to their physical condition and the road conditions.
- The electric wheelchair is suitable for driving on flat roads. Damage



may be caused to the transmission and control system when driving on muddy, hollow or uneven roads.

- The backrest angle for the adjustable electric wheelchair with backrest shall not be adjusted when on an incline. The backrest should be kept in the vertical state.

## 7. Daily Maintenance and Service

### Note

Before servicing, press the power switch on the battery box to the "O" state.

- It is strongly recommended to have specialized personnel adjust and replace worn parts or to contact the manufacturer.

Inspection interval	Daily	Weekly	Monthly	Every 3 months	Every 6 months
Battery	✓				
Tire pressure	✓				
Wire		✓			
Hand brake			✓		
Frame				✓	
Controller				✓	
Motor				✓	
Connector				✓	
Seat back cushion					✓
Tire					✓
Electromagnetic brake					✓

Worn parts are replaced as follows (if it is difficult to replace, please contact the manufacturer promptly for a replacement):

1. Replacement of front wheel: loosen the screws with a wrench,

remove the front wheel, install the new front wheel, lock the screws, adjust the screw tightness and make sure the front wheel spins smoothly.

2. Replacement of rear wheel: have specialized personnel replace it or contact the manufacturer.

3. Seat (back) cushion: loosen the screws with a screwdriver, remove the seat (back) cushion, install the new seat (back) cushion and lock the screws with a screwdriver.

4. Replacement of handrail: loosen the screws with a wrench, remove and handrail, fasten the new handrail and lock the screws with a wrench.

Battery: check the remaining battery capacity. If the battery reaches the end of its service life and should be replaced, please contact the supplier

- or the manufacturer or purchase a battery of the same specification locally

Tire pressure: it is recommended to inflate the tires of 200 X 45 - 110 and 310 X 50 - 203 to 260 kpa (maximum 325 kpa) and inflate the tires of 22 X 1.75 to 280 kpa (maximum 345 kpa), which can be adjusted depending on

- weight and air temperature variation; the tire will leak gradually if they are stored for a long time or are not used, this is normal; please carefully read the following instructions to operate the wheelchair: a. when the tire pressure is not sufficient, (1) press the tire evenly with your hands, so that the tire and rim can fit uniformly; (2) inflate the tire to the appropriate state; b. when the tire is deflated, (1) inflate the tire to about 30% of the full air volume, press the tire evenly with your hands, so that the tire and rim can fit uniformly; (2) inflate the tire to the appropriate state.

Wire: check the electrical parts and connecting wires for any damage. If any, please contact the supplier or have specialized personnel repair it. Do not repair it by yourself.

Hand brake: the brake prevents the wheels from moving after the wheelchair is parked and cannot be used during driving; check whether the brake has broken down. If it has, it can be adjusted and resumed.

Frame: the frame surface coating should be wiped with a soft cloth and

- should be kept clean; lubricant is prohibited. If the frame cracks, please contact the supplier.

Service of controller: clean the controller and joystick with a cloth dampened with a neutral diluted cleaner carefully. Never use abrasive materials

- or alcoholic detergents for cleaning. Protect the controller from damage during transportation of the wheelchair.

Motor: check if there is any increase in oil leakage or noise. If any, please

- contact the supplier or manufacturer.

Maintenance of connector reliability: check that the screws and nuts on the body are tightened frequently and promptly handle the problems (if any) to ensure driving safety.

- Seat back cushion: wash the seat cover and backrest with warm water and diluted soapy water. Avoid keeping the wheelchair in a damp place.

Electromagnetic brake: service brake. Let the wheelchair run straight at the maximum speed on a flat asphalt pavement. Release the controller joystick to automatically return it to the original position and measure the

- distance from the time of releasing the joystick to stopping. If the distance is larger than it was originally, the braking effect is reduced; if the distance is more than 1.5m, contact the supplier or manufacturer for repair.

- Maintenance and service of battery:

1. Pay attention to the power indicator on the controller panel: if the green indicator is not lit, charge the battery as soon as possible; If the red indicator is lit, the battery capacity is seriously low. Charge the battery immediately to prevent the battery voltage from getting too low, thus affecting the battery's life.

2. The battery is marked with obvious positive and negative electrode signs and a reliable connector is provided to ensure the normal connection of the circuit. Non-specialized persons should not connect the circuit.

3. The battery is maintenance-free and replenishment of supplemental fluid is not required daily. During charging, the battery temperature will rise, but should not exceed 45°C; if the temperature exceeds 45°C, stop charging until the temperature drops below 35°C. If the wheelchair is parked for a long time, recharge the battery at least once a month.

4. The battery has its service life. If the trip mileage is significantly different

from the nominal mileage after long time of normal operation, please replace the battery.

5. Do not use the battery at temperature of  $\geq 50^{\circ}\text{C}$  or  $\leq -20^{\circ}\text{C}$ .

6. Keep the battery clean and dry. Do not hit the battery with hard objects. Keep the battery properly and keep it in a place out of reach of children.

7. The power switch on the battery box cuts off the battery power and reduces the natural power consumption of the battery. Turn off the power switch on the battery box when the wheelchair is not being used for a long time.

8. "Full capacity": develop the habit of maintaining the battery at full capacity and charge the battery in a timely manner according to usage, so that the battery is at "full capacity" long-term.

9. Replace battery

Press the power switch on the battery box to the "O" position for battery replacement;

(1). If lead-acid batteries is used, left and right battery boxes are provided and each battery box contains a lead-acid battery: red on the battery indicates the positive electrode and black indicates the negative electrode. The battery shall be replaced as follows:

a. Loosen the 6 self-tapping screws from inside of the electric wheelchair (i.e. back of the battery box) and open the back cover, see Figure 22. The methods are same for left side and right side;

b. Take the battery out of the battery box, remove the positive and negative leads with a wrench, install the new battery and affix the positive and negative leads. The remaining wiring harness shall remain unchanged;

Maintenance and service of battery:

c. Pay attention to distinguish between the positive and negative electrodes on both sides of the wiring harness. For the right hand battery connecting wires, connect the red wire with the positive electrode (+) and connect the brown wire with the negative electrode (-); for the battery on the left, connect the red wire with the positive electrode (+) and connect

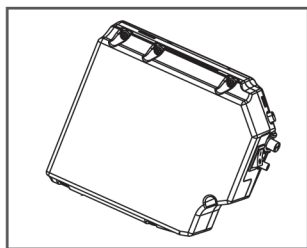

Figure 22

the black wire with the negative electrode (-).

(2). If a lithium battery is used, only one battery box is provided at the right and the battery box only has a lithium battery: red on the battery indicates the positive electrode and black indicates the negative electrode. The battery shall be replaced as follows:

- a. Loosen the 6 self-tapping screws from inside of the electric wheelchair (i.e. back of the battery box) and open the back cover (the illustration is same as that of the lead-acid battery);
- b. Take the battery out of the battery box, separate the connector by hand, install the new battery and replace the connector. The remaining wiring harness shall remain unchanged.

Waste should be disposed of in accordance with the relevant national environmental protection regulations.

► Folding steps: (see Figures 23, 24 and 25)

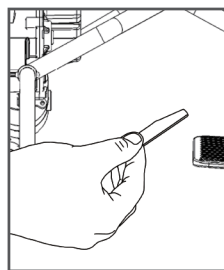

Figure 23  
Fold up the pedals

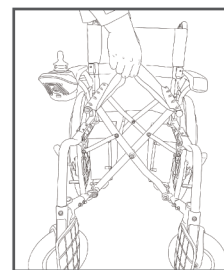

Figure 24  
Lift up the cushion with both hands until the span length cannot be decreased

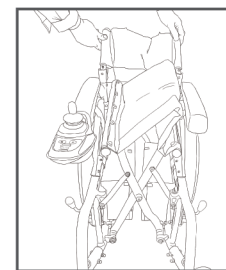

Figure 25  
Put down the folded backrest

- Turn off the power switch on the battery box during transportation.

## 8. Transportation and Storage

### 1. Transportation

- Handle the product gently during transportation. Do not throw, turn over or apply great pressure to it. The goods can be stacked 2 layers at most.

### 2. Storage

This product should be placed in dry and ventilated place and should not be stored in a place subjected to high temperatures and rapid temperature changes; this product should be separated from acid, alkali and other chemical corrosive items.

### 3. Environmental restrictions for transportation and storage

Ambient temperature range:  $-40^{\circ}\text{C}\sim+65^{\circ}\text{C}$

Relative humidity range: 10%~100%

Atmospheric pressure range: 86kPa~106kPa

## 9. Fault Diagnosis and Handling

- If there is no power signal after pressing the power button on the controller, first check whether the power switch on the battery box is in the "I" position; if it is in "O" position, shift the power switch on the battery box to "I" position; At this time, if there is still no power signal when pressing the power button on the controller, the current might be overloading and the fuse is blowout. In this case, the fuse should be replaced. Note: The fuse is only used on the lead-acid battery and is located in the left battery case(see Fig.26). Please turn off the power source when changing the fuse. If the storage battery is a lithium battery, first shift the power button from "I" position to "O" position,and then to "I" position owing to the fact that the lithium battery will cut off the power when it is over - loaded.

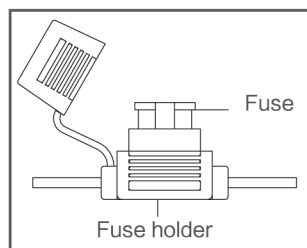

Figure 26

- In case of failure, the controller will sound an alarm and blink, and the corresponding faults can be handled according to the times of the alarm sounds. The diagnostic number displayed by the product's built-in diagnostic function can reflect the nature of the abnormal condition. These abnormal conditions can still be detected without other service tools. Acoustic signal: alarm sounds in cycles.

Diagnostic sound	Diagnostic description	Recommended solutions
1	Low voltage	If the accumulator voltage is low, use it after charging; if the accumulator is damaged, replace it; the battery cannot be charged.
2	Left motor failure	Check the left motor for any loose connecting devices or motor wires.
3	Left brake	Check the left brake for any loose connecting devices or motor wires. Check the brake switch for any damage or poor switch contact.
4	Right motor failure	Check the right motor for any loose connecting devices or motor wires.
5	Right brake	Check the right brake for any loose connecting devices or motor wires. Check the brake switch for any damage or poor switch contact.
6	Overcurrent	Check the brake and motor transmission for any seizure. If the current detected by the ampere meter is not large, the controller may have broken down.
7	Rocker	The rocker is not reset or the rocker wire is broken or the connector has become loose.
8	Controller failure	Consult the service manufacturer.
9	Controller failure	Consult the service manufacturer.

- Most electric wheelchair faults are related to the battery, motor and controller.

No.	Description of faults	Reason analysis and elimination methods
1	The power indicator does not light when the controller power button is pressed	The connection between the battery and the controller is not correct. Re-connect it after inspection.
		The battery voltage is too low. If the indicator still does not light up after the battery is charged, the battery may have reached the end of its service life. Please replace the battery.
		If the controller breaks down, contact the dealer, manufacturer or after-sales service department.
2	Low battery voltage	The connector contact between the battery and the controller is not reliable. Please insert it again.
		The contact resistance between the battery connection is large; if the contact resistance is not large, the contact surface may be oxidized or loosened. Remove the oxide layer or install the connector properly.
		If the battery voltage is too low, it indicates that the battery has reached the end of its service life. Please replace the battery.
3	High battery voltage	The battery's charging voltage is too large. The voltage should not exceed 29.4V after charging is completed.

No.	Description of faults	Reason analysis and elimination methods
4	The motor does not work	If the motor breaks down, contact the dealer, manufacturer or after-sales service department.
		The connector of the motor and the controller is not connected reliably. Please connect it again.
5	Motor brake failure	The motor connector is not connected reliably. Please connect it again.
		The electric brake coil is damaged.
6	No charging indication	The connector of the motor and the controller is not connected reliably. Please connect it reliably again.
		The battery has reached the end of its service life or the charger is damaged. Please replace the battery or charger.
7	Trip distance is shortened after charging	The battery is not charged fully. Please charge the battery again.
		The battery is approaching the end of its service life. Please replace the battery.

## 10. Electromagnetic Compatibility

### Note

- ▶ This product complies with the requirements of the related content in the EMC (electromagnetic compatibility) Standards IEC60601-1-2 and ISO7176-21.
- ▶ The user shall assemble and operate the product according to the instructions of use attached to the electric wheelchair

### Note

- ▶ Portable and radio frequency (RF) communication equipment may affect this product. In order to avoid intense electromagnetic interference, do not use this product near to mobile phone, microwave oven, etc.
- ▶ Please refer to the attachment for the guidelines and manufacturer statement.

### Warning

- ▶ Do not use this product adjacent to or stacked with other equipment. If it is necessary to use the product adjacent to or stacked with other equipment, observe and ensure that the product functions normally under the circumstances.

#### Electric and magnetic environment guidance in use

Guidance and declaration of manufacturer-Electromagnetic emission	
Emission test	Compliance
RF emissions CISPR 11	Group 1
RF emissions CISPR 11	Class B
Emission of harmonics IEC 61000-3-2	NA
Voltage fluctuations / flicker emissions IEC 61000-3-3	NA

#### Guidance and declaration of manufacturer -Electromagnetic emission

Immunity test	Compliance
Electrostatic discharge (ESD) IEC 61000-4-2 ISO7176-21	±8 kV contact ±15 kV Air
Electrical fast transient/bursts IEC 61000-4-4 ISO7176-21	±2 kV for power supply lines
Surge IEC 61000-4-5 ISO7176-21	±1 kV line to line
Voltage dips, short interruptions and Voltage variations on power supply input lines IEC 61000-4-11 ISO7176-21	0% UT 0.5 cycle at 0° ,45° ,90° ,135° ,180° ,225° , 270° and 315°
	0% UT 1 cycle 70% UT 25/30 cycles at 0°
	Voltage short interruptions : 0% UT 250/300 cycles at 0°
Power frequency (50 Hz) magnetic IEC 61000-4-8 ISO7176-21	30 A/m
Radiated RF EM fields IEC 61000-4-3 ISO7176-21	20V/m 80MHz – 2.7GHz 80% AM at 1kHz
Conducted disturbances induced by RF fields IEC 61000-4-6 ISO7176-21	3V/m 0.15MHz – 80MHz 6V in ISM and amateur radio bands between 0.15MHz and 80MHz 80% AM at 1kHz
Note: U <sub>τ</sub> is the a.c. mains voltage prior to application of the test level.	

Test specifications for ENCLOSURE PORT IMMUNITY to RF wireless communications equipment						
Test frequency (MHz)	Band (MHz)	Service	Service	Maximum power (W)	Distance (m)	IMMUNITY TEST LEVEL (V/m)
385	380 - 390	TETRA 400	Pulse modulation 18 Hz	█	0,3	27
450	430 - 470	GMRS 460, FRS 460	FM ±5 kHz deviation 1 kHz sine	█	0,3	28
710	704 - 787	LTE Band 13,17	Pulse modulation 217 Hz	█	0,3	9
745						
780						
810	800 - 960	GSM 800/900, TETRA 800, iDEN 820, CDMA 850, LTE Band 5	Pulse modulation 18 Hz	2	0,3	28
930						
1720	1700 - 1990	GSM 1800; CDMA 1900; GSM 1900; DECT; LTE Band 1,3,4,25; UMTS	Pulse modulation 217 Hz	2	0,3	28
1845						
1970						
2450	2400 - 2570	Bluetooth, WLAN, 802.11 b/g/n, RFID 2450, LTE Band 7	Pulse modulation 217 Hz	2	0,3	28

5240	5100 - 5800	Bluetooth, WLAN, 802.11 b/g/n, RFID 2450, LTE Band 7	Pulse modulation 217 Hz	█	0,3	28
5500						
5785						
NOTE If necessary to achieve the IMMUNITY TEST LEVEL, the distance between the transmitting antenna and the ME EQUIPMENT or ME SYSTEM may be reduced to 1 m. The 1 m test distance is permitted by IEC 61000-4-3.						

## 11. After-sales Service

### Warranty instructions:

- Our company is responsible for return, replacement and repair if any quality problem not caused by human factors occurs to this product within one week after the date of sale. Our company will provide the free repairs if any quality problem not caused by human factors occurs to this product within one year after the date of sale under normal operation and storage conditions. For any quality problem of this product after one year after the date of sale, the user can send it to the company's after-sales service department, office or dealer with an invoice and warranty card and our company will repair the parts and components at a reasonable charge. If the user fails to provide the invoice, the warranty period will be extended by one month according to the company's batch number or date of production. Foreign users may send the product to our company for repair at their own expense. Service life: 3 years (except for wearing parts).
- The warranty period of important parts is as follows:  
The following conditions are not covered by the warranty:

No.	Parts	Warranty period
1	Frame	3 years
2	Controller	1 year
3	Motor	1 year
4	Lithium battery	1 year
5	Lead-acid batteries	Half a year

- ① Wearing parts: seat back cushion, tire, handrail and battery;
- ② Faults caused by unauthorized demolition, repair and transformation of this product;
- ③ Faults caused by accidental drops during operation and transportation;
- ④ Damage caused by improper use or other accidental and human factors;
- ⑤ Faults caused by failing to comply with the correct operation methods in these instructions;
- ⑥ Damage caused by unpredictable natural disasters (such as fires, earthquakes and floods);
- ⑦ No warranty card;
- ⑧ The product model recorded on the warranty card is inconsistent or is modified.

The number is displayed on the cross bar of each electric wheelchair.













#### Note

If repairs are necessary, you can provide a circuit diagram, parts list and data required for repair. If the circuit has any problems, contact the manufacturer.

## 12. Supplementary Instructions

Name and content of toxic and hazardous substances or elements in the electric wheelchair

Size and weight parameter table of electric wheelchair

Model	Total length mm	Total width mm	Total height mm	Seat width mm	Seat height mm	Seat depth mm	Hand rail height mm	Hand-rail spacing mm	Se-atrest height mm	Ground clearance of foot support mm	Front wheel inch	Rear wheel inch	Max. load ca- pacity Kg	Feature description
														
D210B	980	670	870	440	430	430	225	440	395	100	8	12	100	Fixed arms, movable feet, backrest folding
D210BL	980	670	870	440	430	430	225	440	395	100	8	12	100	Fixed arms, movable feet, backrest folding
D210D	970	670	870	420	490	460	225	465	400	90-130	8	12	100	Movable arms, movable feet, backrest folding
D210DL	970	670	870	420	490	460	225	465	400	90-130	8	12	100	Movable arms, movable feet, backrest folding

Please be noted we reserve the right to change the technology and appearance of this product without prior notice!

Packing list for electric wheelchair

No.	Name	Quantity	Remarks
1	Electric wheelchair	1	
2	Accessory Tool	Allen wrench	1
		Socket wrench	1
3	Anti-roll wheel set	1	One on both left and right
4	Manual	1	

The damaged accessories are recommended to return to the original factory for repair and replacement after contacting with the manufacturer.

The company is not responsible for the consequences of violations if the customer purchases accessories arbitrarily.